

**JISKOOT™ QUALITY SYSTEMS**

DATA SHEET S060-1105-5

# Sample Receiver Cleaning

**Introduction**

There are two methods that may be used to provide a receiver cleaning system – a hot water based system and a solvent based system. A hot water based system may be used on products that can easily be cleaned with water at 70°- 80° C. The intent of the system is to provide a clean “dry” receiver by fully washing and flushing all the walls, couplings and internal pipework.

**Solvent method**

The can cleaning facility uses a solvent supply and an air supply. Because the use of solvent is by nature a hazard, the operation is made within an enclosure with a ducted fume extractor to prevent escape of vapours by using a small negative pressure.

A dual pumped loop system is used to minimise the use of clean solvent, which is required for the final rinse of the receiver.

The can cleaning facility is fully automated by the use of solenoids, relays and adjustable timers. The cleaner is provided with a replaceable insert to allow either 9 or 18 litre receivers to be washed. A proximity detector is fitted to prevent operation of the cleaner without a receiver in place.

It is assumed that all receivers fitted to the cleaner will have been hand drained to minimise the amount of residue remaining, a tun dish is provided piped to drain to facilitate this.

The receiver is opened and the lid set aside, it is then inserted and locked down. A central jet probe enters the main opening of the receiver to clean the base.

The primary solvent wash is with a reservoir of re-used "dirty solvent" in which the receiver residue will be collected, this is recycled through the receiver for a fixed time to wash heavy residue from the walls. At the end of this primary cleaning cycle, a secondary solvent source is substituted. The secondary clean solvent is pumped into the receiver by a dedicated pump, this is designed to finally rinse the receiver and the rinsed solvent is collected in the dirty solvent reservoir, thus improving the quality. Excess dirty solvent is automatically discharged to drain.

Further protection mechanisms exist to ensure that the reservoirs cannot be overfilled.

As a final process a warm air supply may be blown into the receiver opening to assist full drying.

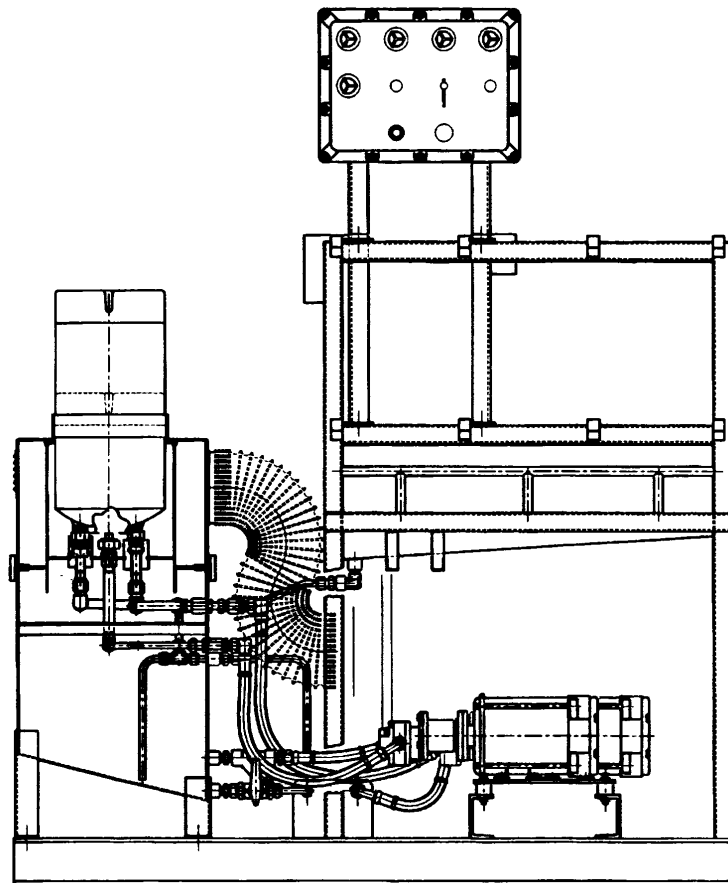

#### MEASUREMENT SYSTEMS

DIVISION HEADQUARTERS  
HOUSTON, TEXAS  
**+1 800 654 3760**

JISKOOT QUALITY SYSTEMS  
HEADQUARTERS  
TUNBRIDGE WELLS, KENT, UK

**+44 1892 518000**

ms-jiskootinformation@c-a-m.com

JISKOOT QUALITY SYSTEMS  
US TECH CENTER  
HOUSTON, TEXAS

**+1 281 582 9500**

ms-jiskootsales@c-a-m.com

USA • CANADA • UK • CHINA • UAE • ALGERIA • MALAYSIA • INDIA • KENYA

[www.c-a-m.com/jiskoot](http://www.c-a-m.com/jiskoot)