

# JISKOOT Refined Product Sampling System

TECHNOLOGY



# JISKOOT Refined Product Sampling System

Sampling of refined hydrocarbon liquids for quality, fiscal or density measurement is governed by the ISO 3171, ASTM D 4177 and API 8.2 standards for automatic sampling of petroleum liquids in pipelines.

These standards dictate a number of key design issues and steps that must be considered to ensure a system fully complies with the requirements of the standards.

The steps are as follows:

- Homogeneity of pipeline contents
- Extraction of a flow proportional and representative sample
- Correct sample handling and mixing
- Laboratory analysis
- Prove the system

ISO, EI (IP), API and ASTM compliant

Low inter-batch sample contamination risk

Operator friendly and simple to maintain

Low installation cost

Guaranteed representivity

Fast-loop sampling system

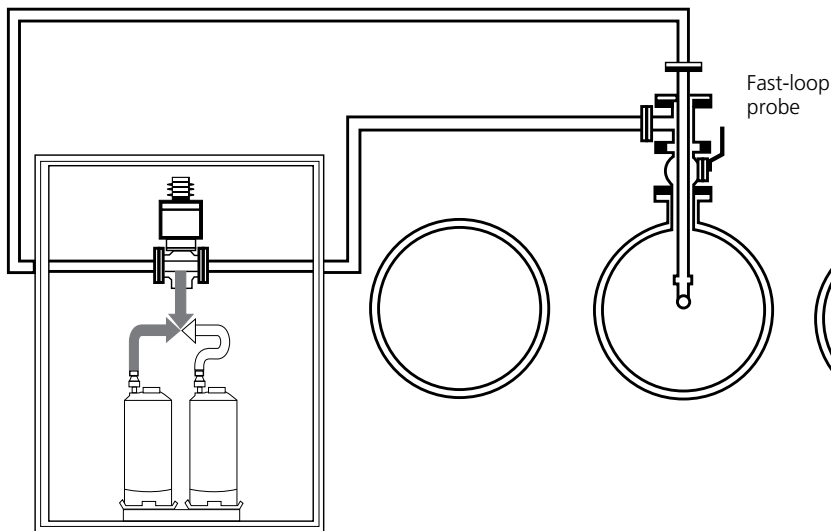

In-line sampling system

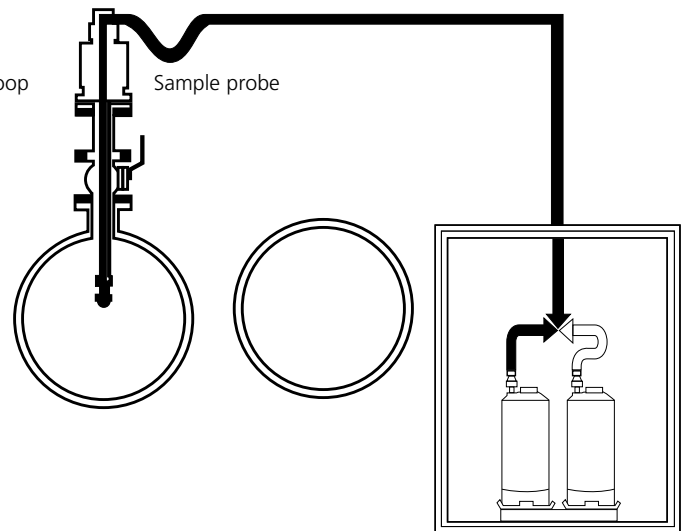

## Applications

- Refined product loading
- Distribution terminals
- Pipeline transfer
- Refineries
- Marine terminals

Automatic sampling can also be used as part of an ISO 9000 quality accreditation program for refined products. Cameron manufactures a range of JISKOOT™ products and fully engineered systems for this application.

Our JISKOOT sampling systems are all designed to ensure maximum representivity and have fast-acting samplers to ensure sufficient sample grabs are taken to avoid sample bias.

Systems are designed to minimize the cross contamination that can occur from different products being transferred through the same pipeline.

The sample storage and handling equipment is designed to be suitable for the products being sampled and the needs of the laboratory. If the system is to be used for ISO 9000 quality assurance, then the system will include an integral performance monitoring system.

Both in-line and fast-loop systems are available for refined product sampling depending upon application. Fast-loop systems offer the option for online instruments, such as densitometers, to be integrated as part of the sampling loop. This creates a combined sampling and analysis package that can provide continuous liquid density measurement, which can be fed to a metering system for mass transfers. Fast-loop systems provide the maximum reduction in batch cross contamination and the unique design allows for flexible installation.

210 Cell Sampler

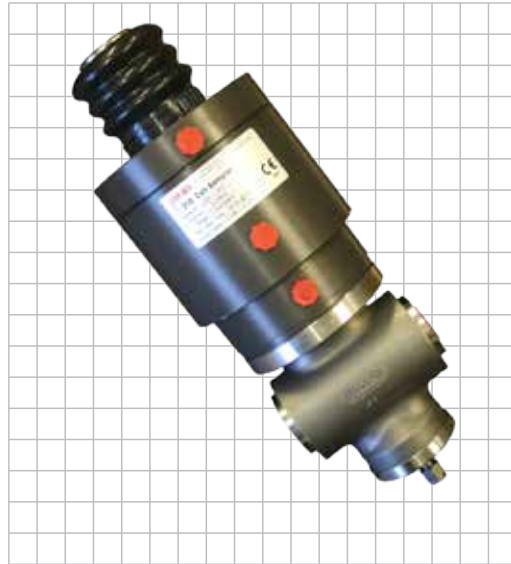

PR Sample Receivers



**NORTH AND SOUTH AMERICA**

14450 JFK Blvd.  
Houston, TX 77032  
USA  
Tel 1 281 582 9500  
ms-us@c-a-m.com

**EUROPE, AFRICA, CASPIAN AND RUSSIA**

JISKOOT Technology Centre  
Longfield Road  
Tunbridge Wells  
Kent, TN2 3EY  
United Kingdom  
Tel 44 1892 518000  
ms-jiskootuksales@c-a-m.com

**ASIA PACIFIC**

Suite 16.02 Menara AmFirst  
No. 1 Jalan 19/3  
46300 Petaling Jaya  
Selangor Darul Ehsan  
Malaysia  
Tel 603 7954 0145  
ms-kl@c-a-m.com

**MIDDLE EAST**

Level 9, Al Jazira Club Tower A  
PO Box 47280, Muroor Road  
Abu Dhabi  
United Arab Emirates  
Tel 971 2 596 8400  
ms-uk@c-a-m.com

Learn more about measurement at:

[www.c-a-m.com/measurement](http://www.c-a-m.com/measurement)



**ALGERIA • CANADA • CHINA • INDIA • MALAYSIA • RUSSIA • UAE • UK • USA**

**HSE Policy Statement**

At Cameron, we are committed ethically, financially and personally to a working environment where no one gets hurt and nothing gets harmed.